



OPERATION & CARE MANUAL

ELITE SERIES WARMER

1.5ft³ - P-2205

2.5ft³ - P-2210

3.5ft³ - P-2220

120V



P-2205
(shown with optional timer)



P-2220

BLANKET WARMING CABINET OPERATION & CARE

INDEX

Transport and Storage	1
Delivery	1
Unpacking	1
Safety Procedures and Precautions	2

Installation

Preparation	3
Electrical Information & clearance requirements	3
General warnings	4
Guidance and manufacturer's declaration – electromagnetic emissions & electromagnetic immunity	4-5
Recommended separation distance	5
General Information	6
Dimension drawings, weights & capacities	7

Operating Instructions

Blanket Control Features	8-9
Blanket Chamber Operational Procedures	10

Care and Cleaning

Cleaning and Preventative Maintenance	11
Protecting Stainless Steel Surfaces	11
Cleaning Agents	11
Cleaning Materials	11
Care and Cleaning	12
Clean the Unit Regularly	12

Troubleshooting Guide 13

Service Parts Lists and Drawings 14-16

Wire Diagram

Always refer to wire diagram(s) included with the unit for most current version.

Warranty

Transportation Damage and Claims	Back Cover
Limited Warranty	Back Cover

BLANKET WARMING CABINET

TRANSPORT AND STORAGE

Transport and Storage Environmental Conditions (not to exceed 15 days)

- Ambient temperature range of -40 to +159°F (-40° to +70°C)
- Relative humidity range of 10% to 100%, including condensation
- Atmospheric pressure range of 50KPa to 106KPa

UNPACKING AND SET-UP

DELIVERY

The Pedigo Blanket Warming Cabinet has been thoroughly tested and inspected to insure only the highest quality unit is provided. Upon receipt, check for any possible shipping damage and report it at once to the delivering carrier. See *Transportation Damage and Claims section located in this manual.*

This appliance, complete with unattached items and accessories, may have been delivered in one or more packages. Check to ensure that all standard items and options have been received with each model as ordered.

Save all the information and instructions packed with the appliance. Complete and return the warranty card to the factory as soon as possible to assure prompt service in the event of a warranty parts and labor claim.

This manual must be read and understood by all people using or installing the equipment model. Contact the Pedigo service department if you have any questions concerning installation, operation, or maintenance.

NOTE: All claims for warranty must include the full model number and serial number of the unit.

UNPACKING

1. Carefully remove the appliance from the carton or crate.

NOTE: Do not discard the carton and other packaging material until you have inspected the unit for hidden damage and tested it for proper operation.

2. Read all instructions in this manual carefully before initiating the installation of this appliance.

DO NOT DISCARD THIS MANUAL.

This manual is considered to be part of the appliance and is to be provided to the owner or manager of the business or to the person responsible for training operators. *Additional manuals are available from the Pedigo service department.*

3. Remove all protective plastic film, packaging materials, and accessories from the appliance before connecting electrical power.

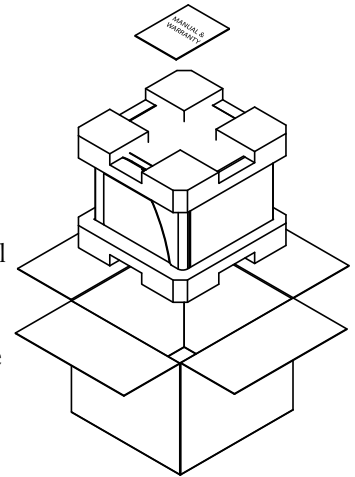

SAFETY PROCEDURES AND PRECAUTIONS

Knowledge of proper procedures is essential to the safe operation of electrically energized equipment. In accordance with generally accepted product safety labeling guidelines for potential hazards, the following signal words and symbols may be used throughout this manual.



DANGER

Used to indicate the presence of a hazard that **will** cause severe personal injury, death, or substantial property damage if the warning included with this symbol is ignored.



WARNING

Used to indicate the presence of a hazard that **can** cause personal injury, possible death, or major property damage if the warning included with this symbol is ignored.



CAUTION

Used to indicate the presence of a hazard that can or will cause minor or moderate personal injury or property damage if the warning included with this symbol is ignored.

CAUTION

Used to indicate the presence of a hazard that can or will cause minor personal injury, property damage, or a potential unsafe practice if the warning included with this symbol is ignored.

NOTE:

Used to notify personnel of installation, operation, or maintenance information that is important but not hazard related.

1. Pedigo blanket warmers are intended for warming cotton blankets **ONLY**. No other use for this device is authorized or recommended.
2. This device is intended for use in commercial establishments where all operators are familiar with the purpose, limitations, and associated hazards of this device. Operating instructions and warnings must be read and understood by all operators and users.
3. Any troubleshooting guides, component views, and parts lists included in this manual are for general reference only and are intended for use by qualified technical personnel.
4. This manual should be considered a permanent part of this device. This manual and all supplied instructions, diagrams, schematics, parts lists, notices, and labels must remain with the device if the item is sold or moved to another location.

NOTE

Pedigo warmers should not be left unattended for periods of more than 24 hours. In case of absences longer than 24 hours, disconnect the warmer from its power source.

NOTE

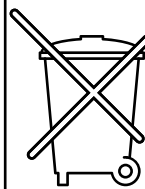

For equipment delivered for use in any location regulated by the following directive:

DO NOT DISPOSE OF ELECTRICAL OR ELECTRONIC EQUIPMENT WITH OTHER MUNICIPAL WASTE.

PREPARATION

Before operating the cabinet, clean both the interior and exterior of the unit with a damp cloth and mild soap solution. Wipe with an appropriate disinfectant.

ELECTRICAL INFORMATION



The power specifications are located on the unit identification rating tag. This rating tag is permanently attached to the unit and must be located to verify power requirements.

UL FILE #	<input style="width: 80%;" type="text"/>	MADE IN USA
MODEL	<input style="width: 100%;" type="text"/>	
WATTS	<input style="width: 100%;" type="text"/>	
VOLTS	<input style="width: 20%;" type="text"/> 1 PH	<input style="width: 20%;" type="text"/> Hz
SERIAL#	<input style="width: 100%;" type="text"/>	

Electrical	P-2205	P-2210	P-2220
120 V.A.C. 50/60 Hz, 1ph Safety Class I Equipment	5.0 Amps, 0.6 kW NEMA 5-15P 15A - 125V Plug Hospital Grade	5.0 Amps, 0.6 kW NEMA 5-15P 15A - 125V Plug Hospital Grade	6.7 Amps, 0.8 kW NEMA 5-15P 15A - 125V Plug Hospital Grade

Wire diagram is located under top cover of unit.



Hazardous
Voltage Present

Grounding reliability can only be achieved when equipment is connected to an equivalent receptacle marked "Hospital Grade."



Medical Equipment classified by Underwriters Laboratories with Respect to Electrical Shock, Fire and Mechanical Hazards only, in Accordance with UL 60601-1 and CAN/CSA C22.2 No. 601.1.



Clearance requirements:

- 2" from rear
- 1" from sides
- 3/4" from bottom

DANGER

**ENSURE POWER SOURCE
MATCHES VOLTAGE STAMPED
ON APPLIANCE NAMEPLATE.**

DANGER

**DO NOT use this warming cabinet
in the presence of flammable
anesthetic mixture (with air or
with oxygen or nitrous oxide).
THIS COULD RISK AN EXPLOSION!**

GENERAL WARNINGS

The Elite Series warmer requires special precautions regarding EMC and needs to be installed and put into service according to the EMC information provided in the accompanying documents.

Portable and mobile RF communications equipment can affect medical electrical equipment.

The Elite Series Warmer has a detachable power cord that is ~2.5m in length.

WARNING: A risk of increased emissions or decreased immunity may result if the power cord attached is altered or a manufacturer supplied power cable is not used.

The Elite Series Warmer should not be used adjacent to or stacked with other equipment.

WARNING: observe to verify normal operation if it is necessary to use adjacent to or stacked with other equipment.

Guidance and manufacturer's declaration – electromagnetic emissions

The Elite Series Warmers are intended for use in the electromagnet environment specified below. The customer or the end user of the Elite Series Warmer should assure that it is used in such an environment.

Emissions test	Compliance	Electromagnetic environment - guidance
RF emissions CISPR 11	Group 1	The Elite Series Warmer uses RF energy only for it internal function. Therefore, its RF emissions are very low and are not likely to cause any interference in nearby electronic equipment.
RF emissions CISPR 11	Class B	The Elite Series Warmer is suitable for use in all establishments, including domestic establishments and those directly connected to the public low-voltage power supply network that supplies buildings used for domestic purposes.
Harmonic emissions IEC 61000-3-2	Class A	
Voltage fluctuations/Flicker emissions IEC 61000-3-3	Complies	

Guidance and manufacturer's declaration – electromagnetic immunity

The Elite Series Warmer is intended for use in the electromagnet environment specified below. The customer or the end user of the Elite Series Warmer should assure that it is used in such an environment.

Immunity test	IEC 60601 test level	Compliance level	Electromagnetic environment - guidance
Electromagnetic discharge (ESD) IEC 61000-4-2	±6 kV contact ±8 kV air	±6 kV contact ±8 kV air	Floors should be wood, concrete or ceramic tile. If floors are covered with synthetic material, the relative humidity should be at least 30%.
Electrical fast transient/burst IEC 61000-4-4	±2 kV for power supply lines ±1 kV for input/output lines	+2 kV for power supply lines	Mains power quality should be that of a typical commercial or hospital environment. The Elite Series Warmer does not have any input/output lines.
Surge IEC 61000-4-5	±1 kV differential mode ±2 kV common mode	±1 kV differential mode ±2 kV common mode	Mains power quality should be that of a typical commercial or hospital environment.
Voltage dips, short interruptions and voltage variations on power supply input lines IEC 61000-4-11	<5 % UT (>95 % dip in UT) for 0.5 cycle 40 % UT (60 % dip in UT) for 5 cycles 70 % UT (30 % dip in UT) for 25 cycles <5 % UT (>95 % dip in UT) for 5 sec	<5 % UT (>95 % dip in UT) for 0.5 cycle 40 % UT (60 % dip in UT) for 5 cycles 70 % UT (30 % dip in UT) for 25 cycles <5 % UT (>95 % dip in UT) for 5 sec	Mains power quality should be that of a typical commercial or hospital environment. If the user of the Elite Series Warmer requires continued operation during power mains interruptions, it is recommended that the Elite Series Warmer be powered from an uninterruptible power supply or a battery.
Power frequency (50/60 Hz) magnetic field IEC 61000-4-8	3 A/m	3 A/m	Power frequency magnetic fields should be at levels characteristic of a typical location in a typical commercial or hospital environment.

NOTE UT is the a.c. mains voltage prior to application of the test level.

The essential performance of the Elite Series Warmer is to not exceed internal temperature of 250 degrees F (+10%) at any setting.

Guidance and manufacturer's declaration - electromagnetic emissions

The Elite Series Warmer is intended for use in the electromagnetic environment specified below. The customer or the end user of the Elite Series Warmer should assure that it is used in such an environment.

Immunity test	IEC 60601 test level	Compliance level	Electromagnetic environment - guidance
Conducted RF IEC 61000-4-6	3 Vrms 150 kHz to 80 MHz	3 V	Portable and mobile RF communications equipment should be used no closer to any part of the Elite Series Warmer, including cables, than the recommended separation distance calculated from the equation applicable to the frequency of the transmitter. Recommended separation distance $d = [3.5/3] \sqrt{P}$ $d = [3.5/3] \sqrt{P}$ 80 MHz to 800 MHz $d = [7/3] \sqrt{P}$ 800 MHz to 2.5 GHz where P is the maximum output power rating of the transmitter in watts (W) according to the transmitter manufacturer and d is the recommended separation distance in metres (m). Field strengths from fixed RF transmitters, as determined by an electromagnetic site survey, ^a should be less than the compliance level in each frequency range. ^b Interference may occur in the vicinity of equipment marked with the following symbol: 
Radiated RF IEC 61000-4-3	3 V/m 80 MHz to 2.5 GHz	3 V/m	

NOTE 1 At 80 MHz and 800 MHz, the higher frequency range applies.

NOTE 2 These guidelines may not apply in all situations. Electromagnetic propagation is affected by absorption and reflection from structures, objects and people.

^a Field strengths from fixed transmitters, such as base stations for radio (cellular/cordless) telephones and land mobile radios, amateur radio, AM and FM radio broadcast and TV broadcast cannot be predicted theoretically with accuracy. To assess the electromagnetic environment due to fixed RF transmitters, an electromagnetic site survey should be considered. If the measured field strength in the location in which the Elite Series Warmer is used exceeds the applicable RF compliance level above, the Elite Series Warmer should be observed to verify normal operation. If abnormal performance is observed, additional measures may be necessary, such as reorienting or relocating the Elite Series Warmer.

^b Over the frequency range 150 kHz to 80 MHz, field strengths should be less than [VI] V/m.

Guidance and manufacturer's declaration – electromagnetic immunity Recommended separation distance between portable and mobile RF communications equipment and the Elite Series

The Elite Series Warmer is intended for use in an electromagnetic environment in which radiated RF disturbances are controlled. The customer or the user of the Elite Series Warmer can help prevent electromagnetic interference by maintaining a minimum distance between portable and mobile RF communications equipment (transmitters) and the Elite Series Warmer as recommended below, according to the maximum output power of the communications equipment.

Rated maximum output power of transmitter W	Separation distance according to frequency of transmitter m		
	150 kHz to 80 MHz $d = \left[\frac{3.5}{3} \right] \sqrt{P}$	80 MHz to 800 MHz $d = \left[\frac{3.5}{3} \right] \sqrt{P}$	800 MHz to 2.5 GHz $d = \left[\frac{7}{3} \right] \sqrt{P}$
0.01	0.117	0.117	0.233
0.1	0.369	0.369	0.738
1	1.167	1.167	2.333
10	3.689	3.689	7.379
100	11.667	11.667	23.333

For transmitters rated at a maximum output power not listed above, the recommended separation distance d in meters (m) can be estimated using the equation applicable to the frequency of the transmitter, where P is the maximum output rating of the transmitter in watts (W) according to the transmitter manufacturer.

NOTE 1 At 80 MHz and 800 MHz, the separation distance for the higher frequency range applies.

NOTE 2 These guidelines may not apply in all situations. Electromagnetic propagation is affected by absorption and reflection from structures, objects and people.

GENERAL INFORMATION

Specifications:

- Single-chamber warming cabinet
- White epoxy-coated steel exterior casing and interior insert
- Single pane, energy efficient, e-coated glass window in door allows for inventory observation
- Easy, hands-free door release
- Door is fully gasketed and hinged on the right side of the unit
- WarmRight® technology utilizes multiple zone heating that monitors surfaces for safe temperature ranges
- Elite P-2220 includes a heated center shelf
- Furnished with four (4) 3/4" (19mm) non-skid rubber feet
- Optional casters available

Control:

- Electronic control
- Efficient, balanced heating system allows for low energy consumption and minimal heat loss
- Adjustable temperature range of 37 - 82°C (98 - 180°F)

- Operates in Celsius or Fahrenheit
- Four digit L.E.D. display
- On/Off key
- Up and down arrow keys
- Actual temperature key
- Interior light key
- Built-in speaker for audible feedback
- Built-in button lock-out feature on control

Additional features:

- L.E.D. interior lighting casts a comforting blue glow with two (2) different intensity settings, and OFF mode.
- In the event of a power failure, the cabinet will remember its programming and begin to operate as before when power is restored.
- A warming shut-off system, separate from the electronic control, prevents overheating.
- Timer (optional) allows the user to program the control to automatically turn on and off at a selected time.

DIMENSIONS

Clearance requirements:
 2" from rear
 1" from sides
 3/4" from bottom

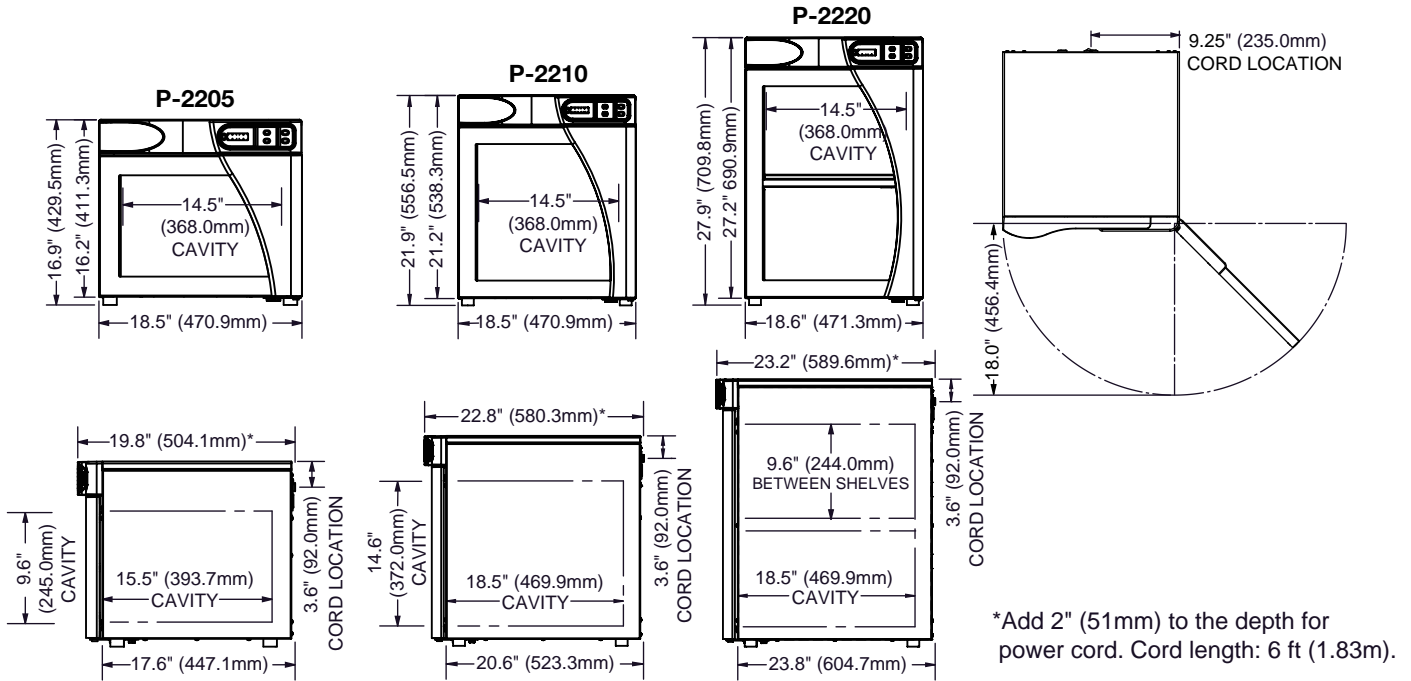

BLANKET CONTROL FEATURES

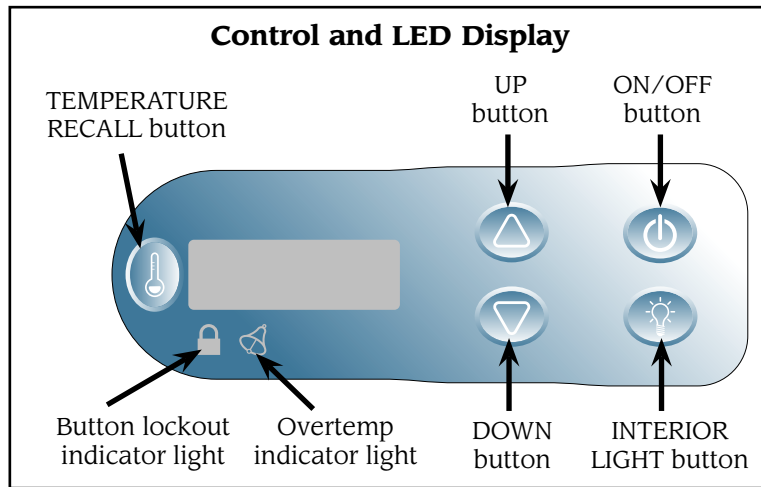

CONTROL PANEL BUTTONS

ON/OFF BUTTON

 Press the ON/OFF button to power on the control. Press and hold the ON/OFF button for three (3) seconds to power off the control.

INTERIOR LIGHT BUTTON

 Press INTERIOR LIGHT button to toggle blue interior LED light intensity to high, low, or off.

UP AND DOWN ARROW BUTTONS

 Used to increase or decrease the temperature set-point. On units with optional timer installed the arrow buttons are used to increase or decrease time, date, auto-start, and auto-stop times.



TEMPERATURE RECALL BUTTON

 Press the TEMPERATURE RECALL button to view the actual cavity temperature. The display will show the actual cavity temperature for five (5) seconds before reverting back to displaying the current temperature set-point.

L.E.D. DIGITAL DISPLAY

The control has a four-digit L.E.D. display.

AUDIBLE BUTTON FUNCTION

The warmer's audible button function can be turned ON or OFF.

1. While the warmer is OFF, press and hold the DOWN ARROW button for four (4) seconds.
2. The display will show the current audible button status, 0 (OFF) or 1 (ON). Press the UP or DOWN arrows to toggle between the two states.



L.E.D. DISPLAY STATUS INDICATORS

OVERTEMP INDICATOR LIGHT

 This indicator will illuminate and an alarm will sound if the control senses a temperature of 195°F (91°C) or higher. The alarm can be muted by pressing the ON/OFF button.

ERROR ACKNOWLEDGEMENT

 To clear or acknowledge an error, press the ON/OFF button. Press the ON/OFF button to acknowledge the periodic alarm. If the alarm continues or returns, the warmer is still experiencing an error and may need service.

BUTTON LOCKOUT INDICATOR LIGHT

 The lock indicator light will illuminate when the control lock feature is engaged. Press the ON/OFF button and UP ARROW simultaneously to lock the control. Press the ON/OFF button and DOWN ARROW button simultaneously to unlock the control.

POWER FAIL DETECTION

If the power fails for any reason while heating, the warmer will retain its current operating state in memory. The control will resume operating after the power is restored. In order to alert the user that the power has failed, the decimal place on the first digit will flash. Press the ON/OFF key to acknowledge the power failure and restoration.

NOTE: If the timer option is installed, the warmer must be off for more than 60 seconds to signal a power failure alarm. When acknowledging a power interruption, the display will show the hours and minutes that the control has been off due to the power outage.

TEMPERATURE FORMAT SELECTION

 While the controller is in OFF state, press and hold the TEMPERATURE RECALL button key for four (4) seconds to display the current temperature scale. Press either the UP or DOWN arrows to toggle between Fahrenheit and Celsius.

OPTIONAL BLANKET CONTROL FEATURES

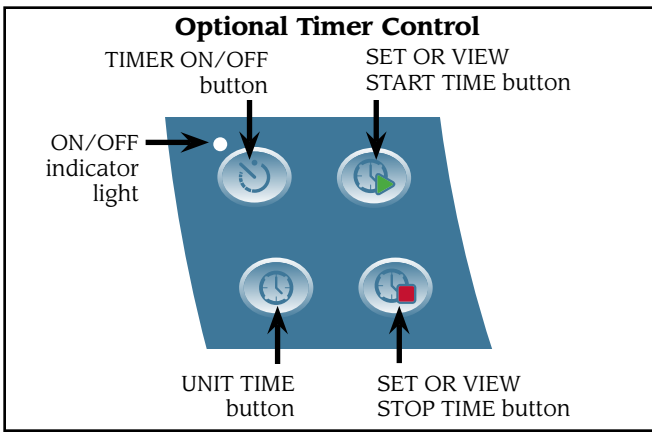

NOTE: If your warmer is not equipped with this optional automated timer feature or you choose not to use it, you do not need to set the time and this section can be skipped.

Unit time must be manually reset for daylight saving time.

Times are always displayed in 24-hour format (HH:MM). Midnight is 00:00. Noon is 12:00. 1:00 p.m. is 13:00.

If the display has changed due to user interaction, it will reset after five (5) seconds of inactivity.

If the start and stop times are the same, the warmer will recognize the OFF time only and the warmer will not turn on without user intervention. This is the best way to set the warmer for the days when is not needed.

TIMER CONTROL PANEL

Blanket warmers with this option have four (4) timer buttons:

TIMER ON/OFF BUTTON



Press the TIMER ON/OFF button to initiate automatic start/stop operation mode. The ON/OFF indicator light next to this button will illuminate when mode is turned on.

UNIT TIME BUTTON



Press to view current time, date, and day and initiate changes to settings.

SET OR VIEW START TIME BUTTON



Press to view current automatic start time and initiate changes to set time.

SET OR VIEW STOP TIME BUTTON



Press to view current automatic stop time and initiate changes to set time.

RESET UNIT TIME BUTTON

Timer option must be OFF to reset the unit time.

NOTE: "E-60" is displayed if the clock is not set or the control has been off too long and the memory has corrupted.

1. If "E-60" is displayed on the screen, press either the UNIT TIME button or the ON/OFF button to acknowledge error.



2. Press and hold the UNIT TIME button for four (4) seconds until the auto-timer ON/OFF indicator light flashes slowly and the display shows the current set time. Press the UP or DOWN buttons to adjust the time by minute or press and hold the UP or DOWN button to adjust time more quickly.



3. Press the UNIT TIME button again to view or set the year. Press the UP or DOWN arrow keys to adjust the year. The year will always adjust by one (1).



4. Press the UNIT TIME button again to set the date. Press the UP or DOWN arrow keys to adjust the date.



5. Press the UNIT TIME button again to set the day code (d1-d7). Press the UP or DOWN arrows keys to adjust the day code. This is an optional step unless you are going to configure the auto-timer to start and/or stop at a different time for each day of the week. Typically Monday=d1, Tuesday=d2, etc., but this is user configurable.



SAME START AND STOP TIMES FOR THE WEEK

Timer option must be OFF to set start time.



1. Press the START TIME button to view the start time for that day.

2. Press and hold the START TIME button for four (4) seconds to set the current day's start time as the same time for every day of the week. The ON/OFF indicator light will flash slowly.



3. Press the UP or DOWN ARROW buttons to change the default start time minutes. Press and hold the arrows to adjust by hours.



4. Press the STOP TIME button to view the stop time for that day.

5. Press and hold the STOP TIME button for four (4) seconds to set the current day's stop time as the same time for every day of the week. The ON/OFF indicator light will flash slowly.



6. Press UP or DOWN ARROW buttons to change stop time. Press and hold the arrows to adjust by hours.



7. When both times are set, allow the ON/OFF indicator light to extinguish and then press and hold the Timer ON/OFF button until the ON/OFF indicator light stays on steadily.

Caution: Activating this mode overrides all individual day programming.

DIFFERENT START AND STOP TIMES FOR EACH DAY OF THE WEEK



Press and hold the UNIT TIME button for eight (8) seconds. The ON/OFF indicator light will flash rapidly. The display will show the current day. Adjust the day by pressing the UP or DOWN arrow keys.



1. Press the START TIME or STOP TIME button to display the start or stop times for that day. Press the UP or DOWN arrow keys to adjust the automatic start and stop times.



2. Press the UNIT TIME button again to display the day. Repeat steps 1-2 for each day of the week.



3. When all days and times are set, allow the ON/OFF indicator light to extinguish and then press and hold the Timer ON/OFF button until the ON/OFF indicator light stays on steadily.



4. The warmer will now turn on and off automatically at the times set for each day.

BLANKET CHAMBER OPERATION PROCEDURES

1. A P-2205, P-2210 or P-2220 appliance should be plugged into a hospital grade, NEMA 5-15P, 120V receptacle. P-2205 & P-2210 cords require 6A or greater rating. P-2220 cords require 10A or greater rating.
 2. Turn on the power switch, which is located at the back of the appliance just above power cord. It is a rocker-type switch with international ON (I) and OFF (O) markings.
 3. **ACTIVATE CONTROL BY PRESSING THE ON/OFF KEY ON CONTROL PANEL ONCE.** The digital L.E.D. display will indicate last temperature set-point of compartment.
 4. **SET DESIRED TEMPERATURE.**
To set the blanket warming temperature, press and hold the UP or DOWN ARROW keys to change the value shown in the display. The temperature set-point range is 37 - 82°C (98 - 180°F).
 5. **LOAD THE CHAMBER WITH DRY, 100% COTTON BLANKETS. DO NOT WARM SYNTHETIC BLEND FABRICS OR ITEMS CONTAINING PLASTIC, RUBBER OR METAL SNAPS, STUDS, HOOKS, ETC.**
Check that the epoxy-coated blanket insert is in place. This blanket insert **MUST** be used to hold blankets. Make certain the cabinet door is securely closed during use.
 6. **ROTATE LOAD OF BLANKETS DAILY.**
Rotate the blankets at the bottom of the load to the top to ensure equal usage. Failure to rotate blankets can cause blankets to discolor.
- Note: Avoid using flammable cabinet cleaning agents, as well as blanket cleaning agents that cause fabric to become brittle over time.**



CAUTION

BLANKET SUPPORT INSERTS MUST BE USED WHEN WARMING BLANKETS.

CAUTION

DO NOT OVERLOAD CABINET. ALLOW 1" GAP BETWEEN BLANKETS AND TOP OF UNIT OR SHELF.

CLEANING AND PREVENTIVE MAINTENANCE

PROTECTING STAINLESS STEEL, EPOXY COATED AND PLASTIC SURFACES



It is important to guard against corrosion in the care of stainless steel surfaces. Harsh, corrosive, or inappropriate chemicals can completely destroy the protective surface layer of stainless steel, epoxy or plastic. Abrasive pads, steel wool, or metal implements will abrade

surfaces causing damage to this protective coating and will eventually result in areas of corrosion. Even water, particularly hard water that contains high to moderate concentrations of chloride, will cause oxidation and pitting that result in rust and corrosion. In addition, many acidic spills left to remain on metal surfaces are contributing factors that will corrode surfaces.

Proper cleaning agents, materials, and methods are vital to maintaining the appearance and life of this appliance. Spilled items should be removed and the area wiped as soon as possible but at the very least, a minimum of once a day. Always thoroughly rinse surfaces after using a cleaning agent and wipe standing water as quickly as possible after rinsing.

CLEANING AGENTS

Use non-abrasive cleaning products designed for use on stainless steel surfaces. Cleaning agents must be chloride-free compounds and must not contain quaternary salts. Never use hydrochloric acid (muriatic acid) on stainless steel surfaces. Always use the proper cleaning agent at the manufacturer's recommended strength. Contact your local cleaning supplier for product recommendations.

CLEANING MATERIALS





The cleaning function can usually be accomplished with the proper cleaning agent and a soft, clean cloth. When more aggressive methods must be employed, use a non-abrasive scouring pad on difficult areas and make certain to scrub with the visible grain of surface metal to avoid surface scratches. Never use wire brushes, metal scouring pads, or scrapers to remove residue.



ANNUAL PREVENTATIVE MAINTENANCE

1. Ensure that the correct Operation and Care Manual is available to all users.
2. Ensure that all users have been properly trained in unit's operation.
3. Do not exceed the unit's capacity.
4. Inspect condition of plug and cord. Replace if damaged.
5. Clean dust from outer vents surrounding the unit and around top of bonnet.
6. Check door gasket integrity. Are there any tears? Is the gasket worn or loose? Make sure seal is tight to unit body. Replace gasket if integrity is compromised.
7. Check the blanket insert and shelf (if applicable). Is the insert in place? Are any pieces missing?
8. Check caster or leg condition. Ensure components are secure and tightly threaded.
9. Check control panel overlay condition. Are there any tears or excessive wear on the graphic? Does the control work properly when buttons are pushed?
10. Check that all control and interior LEDs light up.

Contact Service for immediate repair if any of the above problems exist.

 CAUTION	
  	TO PROTECT SURFACES, COMPLETELY AVOID THE USE OF ABRASIVE CLEANING COMPOUNDS, CHLORIDE BASED CLEANERS, OR CLEANERS CONTAINING QUATERNARY SALTS. NEVER USE HYDROCHLORIC ACID (MURIATIC ACID) ON STAINLESS STEEL. NEVER USE WIRE BRUSHES, METAL SCOURING PADS OR SCRAPERS.

CARE AND CLEANING

The cleanliness and appearance of this equipment will contribute considerably to its operating efficiency. Make certain the cabinet and door gasket are kept free of any debris that may accumulate. Good equipment that is kept clean works better and lasts longer.



CLEAN THE UNIT REGULARLY:



1. Disconnect the cabinet from the power source.
2. Remove all detachable items such as blanket insert. Clean these items separately.



NOTE: Avoid the use of abrasive cleaning compounds, chloride based cleaners, or cleaners containing quaternary salts. Never use hydrochloric acid (muriatic acid) on surfaces.



3. Clean the interior metal surfaces of the cabinet with a damp cloth and any mild commercial detergent. Avoid the use of abrasive cleaning compounds. Rinse surfaces by wiping with sponge and clean warm water. Remove excess water with sponge and wipe dry with a clean cloth or air dry. Leave doors open until interior is completely dry.
4. Interior can be wiped with a sanitizing solution after cleaning and rinsing. This solution must be approved for use on stainless steel surfaces. Replace blanket support assembly.
5. Clean the exterior of the cabinet with a cleaner recommended for powder coated surfaces.
6. Clean the window glass with a standard commercial glass cleaner.
7. Wipe control panel, door vents, door buttons, and door gaskets thoroughly since these areas harbor debris.
8. Wipe door gaskets and control panel dry with a clean, soft cloth.

Always follow appropriate state or local health (hygiene) regulations regarding all applicable cleaning and sanitation requirements.

 DANGER	
	DISCONNECT UNIT FROM POWER SOURCE BEFORE CLEANING OR SERVICING.

DANGER	
	AT NO TIME SHOULD THE INTERIOR OR EXTERIOR BE STEAM CLEANED, HOSED DOWN, OR FLOODED WITH WATER OR LIQUID SOLUTION OF ANY KIND. DO NOT USE WATER JET TO CLEAN.
	SEVERE DAMAGE OR ELECTRICAL HAZARD COULD RESULT.
	WARRANTY BECOMES VOID IF APPLIANCE IS FLOODED

(Listed as Ordinary Equipment.)

TROUBLESHOOTING GUIDE



If your unit is not operating properly, check the following before calling your authorized service agent. Check the power applied to the unit. Verify female end of plug is securely seated in unit and that the male end of plug is in an appropriate, functioning outlet. Is the power circuit breaker switch in rear of unit OK? Check fuses. (See "Fuse Replacement" on page 16.) Has the high limit manual reset tripped? If so, reset. (See "Manual Reset Instructions" below.)

Do not attempt to repair or service beyond this point. Contact manufacturer for nearest authorized service agent. Repairs made by any other service agent without prior authorization by manufacturer will void the warranty on the unit.

This chart is provided for the assistance of qualified technicians only and is not intended for use by untrained or unauthorized service personnel.

Error	Refers to	Action Required
E-10 ES10 ES20 ES30 ES40 ES50 ES60 ES70	Cavity sensor Sensor 1 Sensor 2 Sensor 3 Sensor 4 Sensor 5 Sensor 6 Sensor 7	Sensor is shorted. Software disengages heating pads. User must acknowledge error by pressing ON/OFF button. If error persists, a qualified service technician should test sensor. <ul style="list-style-type: none"> To test sensor: Detach the sensor from side wall. Use an Ohm meter to measure the resistance of the sensor. Check sensor at 32°F (0°C) using a container of ice water. If reading is 32.6 KOhm ±1.5KOhm, replace display. If reading is ±2KOhm, replace sensor. Check wires for integrity. Check for proper and secure connections at the control and terminal block. If necessary, re-secure the faulty connections. Call Service if error persists.
E-11 ES11 ES21 ES31 ES41 ES51 ES61 ES71	Cavity sensor Pad sensor 1 Pad sensor 2 Pad sensor 3 Pad sensor 4 Pad sensor 5 Pad sensor 6 Pad sensor 7	Sensor is open. Software disengages heating pads. User must acknowledge error by pressing ON/OFF button. If error persists, a qualified service technician should test sensor. <ul style="list-style-type: none"> To test sensor: Detach the sensor from unit. Use an Ohm meter to measure the resistance of the sensor. Check sensor at 32°F (0°C) using a container of ice water. If reading is 32.6 KOhm ±1.5KOhm, replace display. If reading is ±2KOhm, replace sensor. Check wires for integrity. Check for proper and secure connections at the control and terminal block. If necessary, re-secure the faulty connections. Call Service if error persists.
P130 P230 P330 P430 P530 P630 P730	Pad 1 Pad 2 Pad 3 Pad 4 Pad 5 Pad 6 Pad 7	Heating pad has not reached set-point temperature within one hour. User must acknowledge error by pressing ON/OFF button. If error persists, a qualified service technician should test the pad(s). <ul style="list-style-type: none"> Turn unit OFF and unplug it from AC power. Use Ohm meter to measure resistance between L:(Line) & N:(Neutral) leads of heater pad. The Ohm readings shall be: <ul style="list-style-type: none"> 120V = 72 Ohm ±10% 230V = 288 Ohm ±10% Call Service if error persists.
E-31 P131 P231 P331 P431 P531 P631 P731	Cavity sensor Pad sensor 1 Pad sensor 2 Pad sensor 3 Pad sensor 4 Pad sensor 5 Pad sensor 6 Pad sensor 7	Sensor reading is above maximum allowable temperature set-point. Software disengages heating pads. User must acknowledge error by pressing ON/OFF button. Allow unit to cool. Call Service if error persists.
E-60	Real Time Clock Checksum Error	Real Time Clock rechargeable battery backup has discharged. Plug unit into outlet for 30 minutes. See "Timer Control Panel" section on page 9 to reset clock.
E-61	Real Time Clock	Real Time Clock not responding. Call Service if error persists.
E-70	Pad Count Error	More pads detected than set for. Hold ON/OFF button for 12 seconds until display shows "Pad#" (# = number of pads selected [3-7]). Press UP or DOWN arrow to adjust to correct number of pads. (P-2205 & P-2210 = 3 pads, P-2220 = 4 pads)
E-80	EEPROM Error	Call Service.
E-83	EEPROM Error	Call Service for help resetting the control.
E-87	EEPROM Error	Stored offsets corrupted. Offsets reset to 0. Control may need a recalibration. Possible bad EEPROM. Call Service if error persists.
E-90	Button stuck	A button has been held down for >60 seconds. Adjust control. Error will reset when the problem has been resolved.

NOTE: All error codes can be cleared using the ON/OFF button.

Manual Reset Instructions: After allowing unit to cool, remove three (3) screws from top cover (on upper edge of the back of unit). Slide top panel toward back of unit (approximately 1/2" [13mm]) and then lift up. Locate the two (2) manual reset buttons in middle of the bonnet. (See "MANUAL RESETS" in bold on service views on following pages.) Firmly push reset button(s). You will hear an audible click when the buttons are reset. If reset button trips again while unit is running, contact a qualified service technician.

CAUTION

THIS SECTION IS PROVIDED FOR THE ASSISTANCE OF QUALIFIED SERVICE TECHNICIANS ONLY AND IS NOT INTENDED FOR USE BY UNTRAINED OR UNAUTHORIZED SERVICE PERSONNEL.

SERVICE PARTS LIST (SEE SERVICE VIEWS ON FOLLOWING PAGES)

LOC	DESCRIPTION	P-2205 P/N	QTY	P-2210 P/N	QTY	P-2220 P/N	QTY
MECHANICAL HARDWARE							
1.	BLANKET SUPPORT, BOTTOM	1011045	1	1011265	1	1011265	1
2.	BLANKET SUPPORT, SIDES	1011046	2	1011264	2	1011358	2
3.	BLANKET SHELF, HEATED*	N/A	-	N/A	-	5012696	1
4.	BOTTOM COVER	1011026	1	1011267	1	1011267	1
5.	BUMPER FEET, RUBBER	FE-29203	4	FE-29203	4	FE-29203	4
6.	DOOR ASSEMBLY	5011206	1	5011584	1	5011606	1
7.	INSULATION	CONTACT FACTORY	-	CONTACT FACTORY	-	CONTACT FACTORY	-
8.	REAR COVER	1011025	1	1011268	1	1011289	1
9.	SIDES	1011024	2	1011269	2	1011288	2
10.	TOP COVER	1011029	1	1011266	1	1011266	1
11.	PLATE, LOWER HINGE	1011240	1	1011240	1	1011240	1
12.	PLATE, UPPER HINGE	1011098	1	1011098	1	1011098	1
ELECTRICAL & CONTROL HARDWARE							
13.	120V POWER CORD*	CD-34906	1	CD-34906	1	CD-35030	1
14.	230V POWER CORD*	CONTACT FACTORY	1	CONTACT FACTORY	1	CONTACT FACTORY	1
15.	BUSHING	BU-29206	3	BU-29206	3	BU-29206	3
16.	BUTTON RETAINER PLATE	1011149	1	1011149	1	1011149	1
17.	CAVITY SENSOR*	SN-34976	1	SN-34976	1	SN-34976	1
18.	CLIP, HEATING PAD	CL-22259	18	CL-22259	18	CL-22259	18
19.	CLIP, PANEL RETAINER	CL-29193	10	CL-29193	10	CL-29193	10
20.	BUTTON COVER	CV-29256	1	CV-29256	1	CV-29256	1
21.	BUTTON COVER (ASSY WITH TIMER CLOCK)	CV-29434	1	CV-29434	1	CV-29434	1
22.	CONTROL BOARD	BA-34867	1	BA-34867	1	BA-34867	1
23.	CONTROL BOARD WITH TIMER CLOCK	BA-34869	1	BA-34869	1	BA-34869	1
24.	COVER, DISPLAY OVERLAY	CV-29177	1	CV-29177	1	CV-29177	1
25.	DISPLAY BOARD	BA-34868	1	BA-34868	1	BA-34868	1
26.	EQUIPOTENTIAL RECEPTACLE (230V)	IS-34928	1	IS-34928	1	IS-34928	1
27.	FUSES (F1, F2) FAST ACTING	FU-34955	2	FU-34955	2	FU-34955	2
28.	HEATING PAD ELEMENT	EL-34838	3	EL-34838	3	EL-34838	4
29.	LATCH, BUTTON	LT-29176	1	LT-29176	1	LT-29176	1
30.	LED ASSEMBLY	5012953	1	5012953	1	5012953	1
31.	POWER SUPPLY BOARD	BA-34965	1	BA-34965	1	BA-34965	1
32.	RELAY BOARD	BA-34953	1	BA-34953	1	BA-34953	1
33.	SENSOR	PR-34837	3	PR-34837	3	PR-34837	4
34.	SPEAKER BOARD	BA-34979	1	BA-34979	1	BA-34979	1
35.	SPRING	SD-29371	1	SD-29371	1	SD-29371	1
36.	STAND-OFFS/SPACERS	SP-33849	11	SP-33849	11	SP-33849	11
37.	SPACERS	SP-29425	9	SP-29425	9	SP-29425	9
38.	SWITCH	SW-34911	1	SW-34911	1	SW-34911	1
39.	THERMOSTAT, AUTO RESET	TT-34908	3	TT-34908	3	TT-34908	4
40.	THERMOSTAT, MANUAL RESET	TT-34907	2	TT-34907	2	TT-34907	2
41.	WASHER, FLAT	WS-23991	1	WS-23991	1	WS-23991	1
42.	WASHER, RUBBER	WS-25056	9	WS-25056	9	WS-25056	9
43.	DOOR LATCH PIVOT ASSY SERVICE KIT*	5013640	1	5013640	1	5013640	1

*NOT SHOWN

PART NUMBERS AND DRAWINGS ARE SUBJECT TO CHANGE WITHOUT NOTICE.

SERVICE PARTS GUIDE

Heating Pad Locations

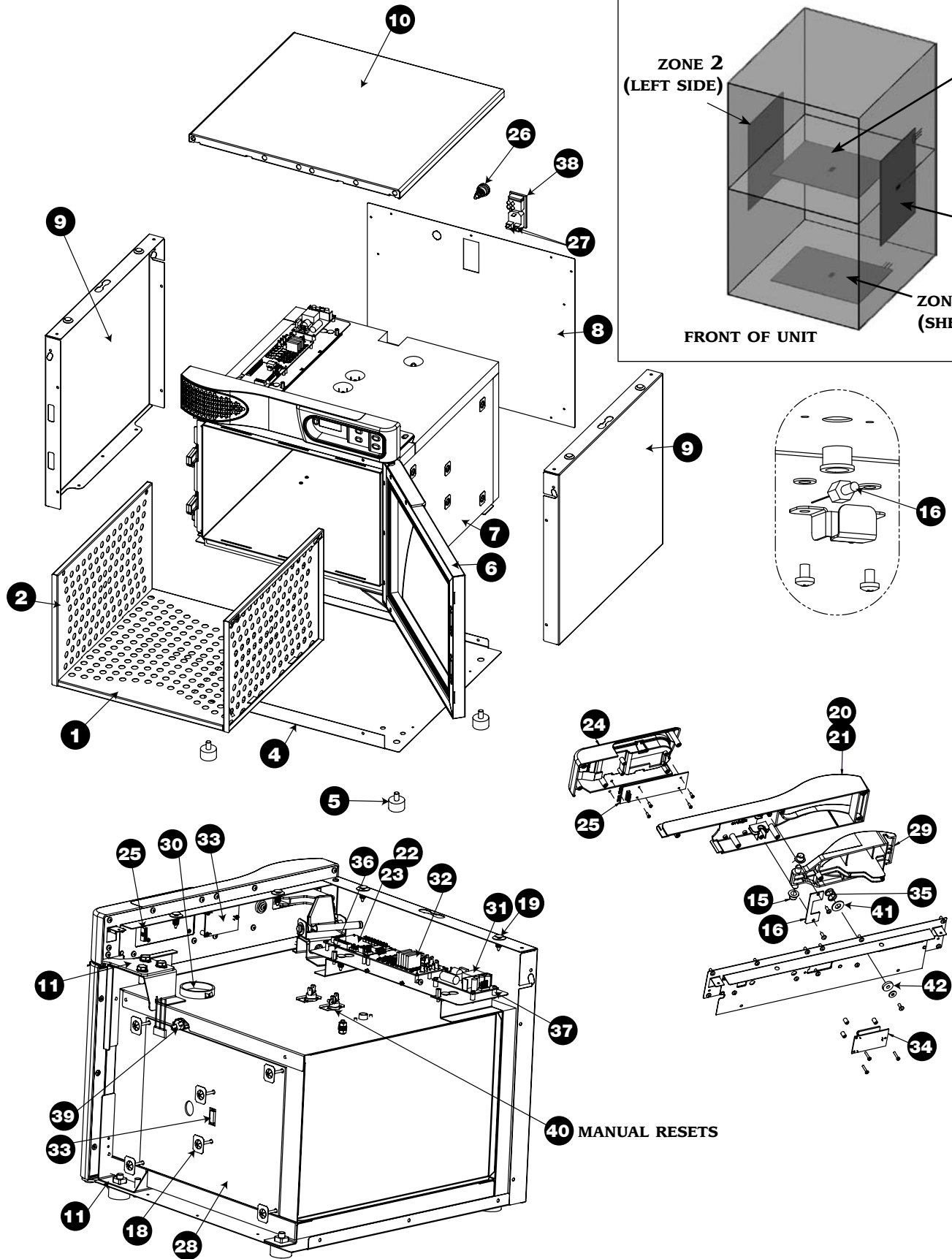
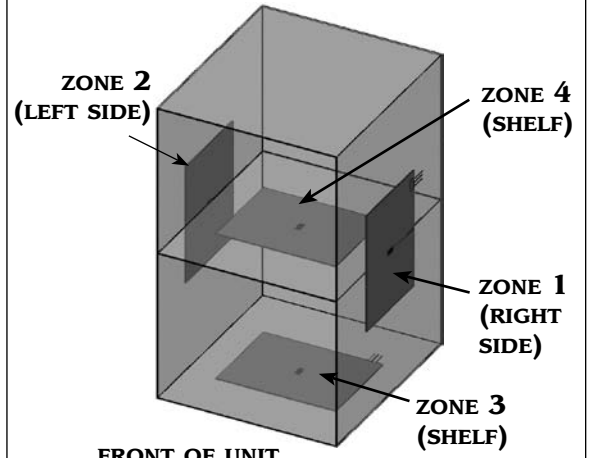

FUSE REPLACEMENT

Fuse replacement:

1. Unplug power cord from wall outlet and ON/OFF switch on unit.
2. Fuse compartment is located directly below the plug receptacle. Use fingernail or thin implement to flip compartment door open.
3. Use fingernail or thin implement to pull fuse drawer out from compartment.
4. Use a thin implement to push fuses up out of drawer.
5. Replace fuse.
6. Push drawer back into compartment.
7. Close compartment door.



OPTIONS & ACCESSORIES PARTS LIST*

OPTIONS AND ACCESSORIES	QTY	P-2205 P/N	QTY	P-2210 P/N	QTY	P-2220 P/N
STEM CASTER, SWIVEL, 3" (76mm)	2	CS-20500	2	CS-20500	2	CS-20500
STEM CASTER, BRAKE, 3" (76mm)	2	CS-29499	2	CS-29499	2	CS-29499

*NOT SHOWN

PART NUMBERS AND DRAWINGS ARE SUBJECT TO CHANGE WITHOUT NOTICE.

Refer to wire diagram under top cover of unit for most current version

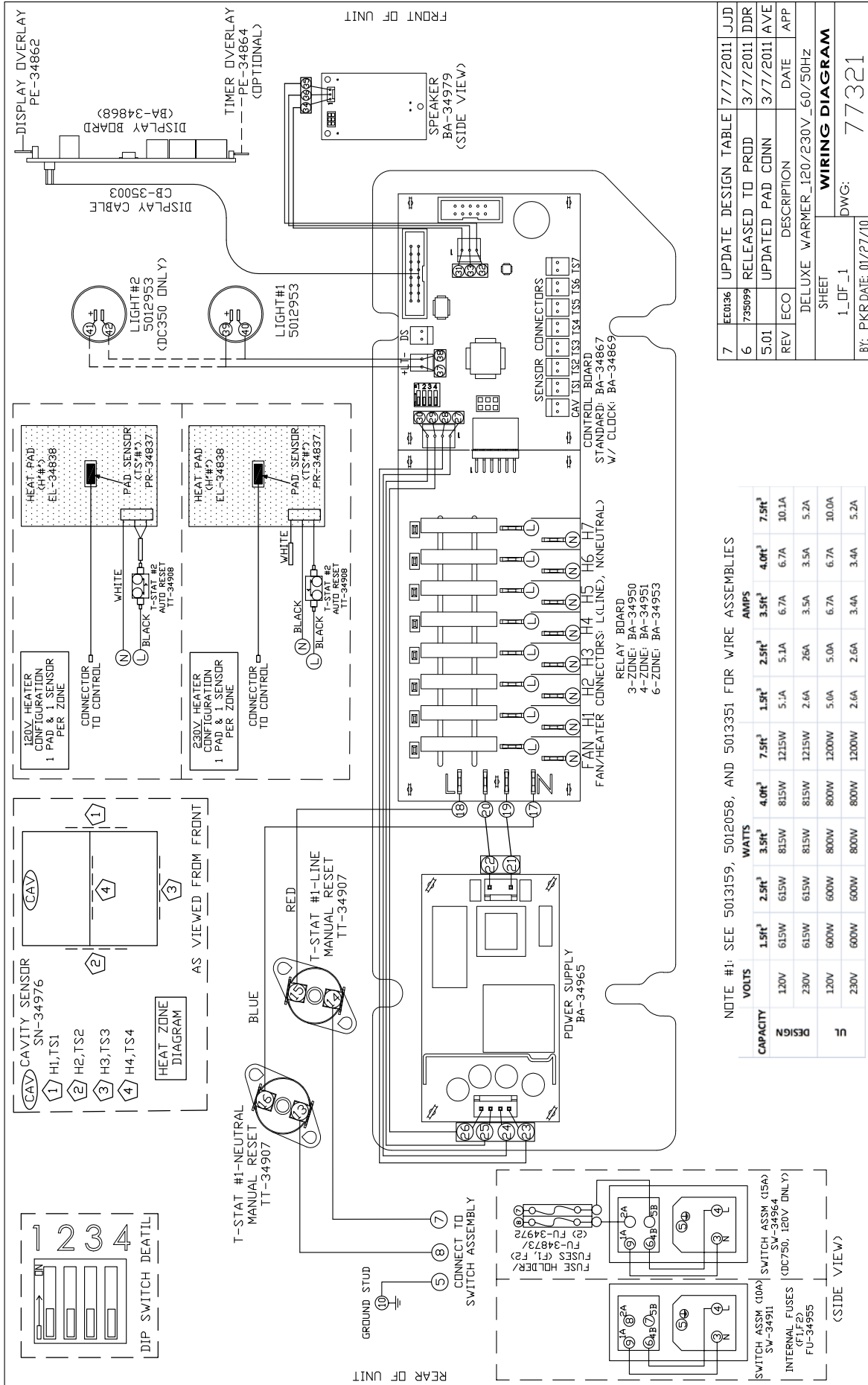

7	EE0086	UPDATE DESIGN TABLE	7/7/2011	JJD
6	735099	RELEASED TO PRODD	3/7/2011	DDR
5.01		UPDATED PAD CONN	3/7/2011	AVE
REV	ECO	DESCRIPTION	DATE	APP
DELUXE WARMER_120/230V_60/50HZ				
SHEET				
1_OF_1				
BY: PKR DATE: 01/27/10				
WIRING DIAGRAM				
DWG: 77321				

NOTE #1: SEE 5013159, 5012058, AND 5013951 FOR WIRE ASSEMBLIES

CAPACITY	DESIGN	VOLTS						WATTS						AMPS					
		1.5t	2.5t	3.5t	4.0t	7.5t	1.5t	2.5t	3.5t	4.0t	7.5t	1.5t	2.5t	3.5t	4.0t	7.5t			
120V	615W	615W	815W	815W	815W	1215W	5.1A	5.1A	6.7A	6.7A	6.7A	6.7A	6.7A	6.7A	10.1A				
230V	615W	615W	815W	815W	815W	1215W	2.6A	2.6A	3.5A	3.5A	3.5A	3.5A	3.5A	5.2A					
120V	600W	600W	800W	800W	800W	1200W	5.0A	5.0A	6.7A	6.7A	6.7A	6.7A	6.7A	10.0A					
230V	600W	600W	800W	800W	800W	1200W	2.6A	2.6A	3.4A	3.4A	3.4A	3.4A	3.4A	5.2A					

TRANSPORTATION DAMAGE AND CLAIMS



All Pedigo Products, Inc. equipment is sold F.O.B. shipping point, and when accepted by the carrier, such shipments become the property of the consignee.

Should damage occur in shipment, it is a matter between the carrier and the consignee. In such cases, the carrier is assumed to be responsible for the safe delivery of the merchandise, unless negligence can be established on the part of the shipper.

1. Make an immediate inspection while the equipment is still in the truck or immediately after it is moved to the receiving area. Do not wait until after the material is moved to a storage area.
2. Do not sign a delivery receipt or a freight bill until you have made a proper count and inspection of all merchandise received.
3. Note all damage to packages directly on the carrier's delivery receipt.
4. Make certain the driver signs this receipt. If he refuses to sign, make a notation of this refusal on the receipt.
5. If the driver refuses to allow inspection, write the following on the delivery receipt:

Driver refuses to allow inspection of containers for visible damage.

6. Telephone the carrier's office immediately upon finding damage, and request an inspection. Mail a written confirmation of the time, date, and the person called.
7. Save any packages and packing material for further inspection by the carrier.
8. Promptly file a written claim with the carrier and attach copies of all supporting paperwork.

We will continue our policy of assisting our customers in collecting claims which have been properly filed and actively pursued. We cannot, however, file any damage claims for you, assume the responsibility of any claims, or accept deductions in payment for such claims.

PEDIGO PRODUCTS, INC. LIMITED WARRANTY

Pedigo Products, Inc. warrants to the original purchaser that any original part that is found to be defective in material or workmanship will, at our option, subject to provisions hereinafter stated, be replaced with a new or rebuilt part.

The labor warranty remains in effect one (1) year from installation or fifteen (15) months from the shipping date, whichever occurs first.

The parts warranty for the cavity fan motor remains in effect one (1) year from installation or fifteen (15) months from the shipping date, whichever occurs first. The parts warranty on all other parts remains in effect three (3) years from installation or thirty-nine (39) months from the shipping date, whichever occurs first.

This warranty does not apply to:

1. Calibration
2. Equipment damage caused by accident, shipping, improper installation or alteration.
3. Equipment used under conditions of abuse, misuse, carelessness or abnormal conditions including equipment subjected to harsh or inappropriate chemicals including but not limited to compounds containing chloride or quaternary salts, poor water quality, or equipment with missing or altered serial numbers.
4. Any losses or damage resulting from malfunction, including loss of contents or consequential or incidental damages of any kind.
5. Equipment modified in any manner from original model, substitution of parts other than factory authorized parts, removal of any parts including legs, or addition of any parts.
6. Collateral or incidental damage as a direct result of servicing equipment built into a wall structure is not covered under warranty. It is the responsibility of the owner to bear all expense related to structural repairs including, but not limited to, external electrical connections and wiring, and the removal or replacement of caulk, grout, tile, or wall covering of any kind. A service access panel for built-in equipment installations is strongly recommended.

This warranty is exclusive and is in lieu of all other warranties, expressed or implied, including the implied warranties of merchantability and fitness for purpose. In no event shall the Company be liable for loss of use, loss of revenue, or loss of contents or revenue, or for indirect or consequential damages. This warranty is in lieu of all other warranties expressed or implied and Pedigo Products, Inc. neither assumes or authorizes any persons to assume for it any other obligation or liability in connection with Pedigo Products, Inc. equipment.

Pedigo Products, Inc.

Record the model and serial numbers of the unit for easy reference. Always refer to both model and serial numbers in your correspondence regarding the unit.

Model: _____

Serial Number: _____

Purchased From: _____

Date Installed: _____ Voltage: _____



Pedigo Products, Inc
4000 S.E. Columbia Way • Vancouver, WA 98661 • U.S.A.
Phone: 800.822.3501 • Fax: 360.696.1700 • www.pedigo-usa.com